

Lms22LED-FC series

Parameters	Units	Conditions	Ratings		
			Min	Typ	Max
Peak emission wavelength	μm	T=300 K, I = 150 mA qCW	2,20	2,23	2,29
FWHM of the emission band	nm	I = 150 mA qCW	200	250	300
Quasi-CW Optical Power	mW	I = 200 mA qCW	0,8	1,6	2,5
Pulsed Peak Optical Power	mW	I=1 A, f=1 kHz, duty cycle 0.1%	20	30	40
Voltage	V	T=300 K, I=200 mA	0,6	-	2,8
Switching time	ns	T=300 K	10	20	30
Operating temperature range	$^{\circ}\text{C}$	-200...+50			
Soldering temperature	$^{\circ}\text{C}$	180			



Light Emitting Diodes Lms22LED-FC series are fabricated from narrow band-gap GaInAsSb/AlGaAsSb heterostructures lattice matched to GaSb substrate.

Spectra at different currents (qCW, T=300 K)

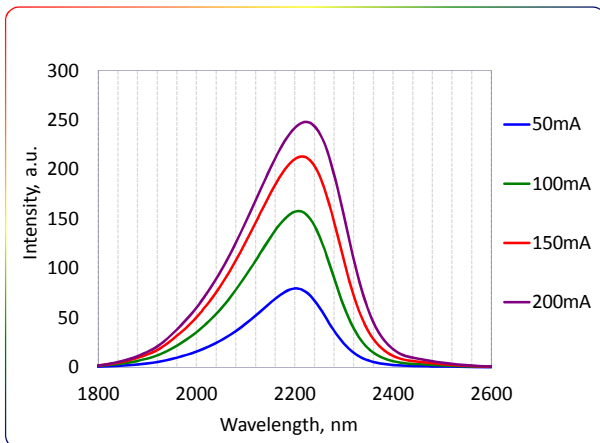

Spectra at different temperatures (qCW, I=150 mA)

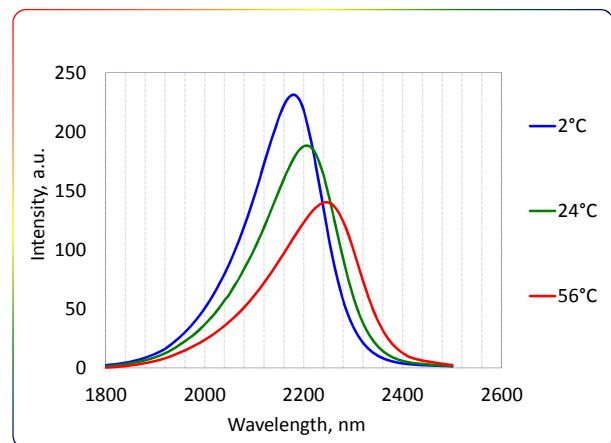

LED Power Characteristic (quasi-CW mode, T=300K)

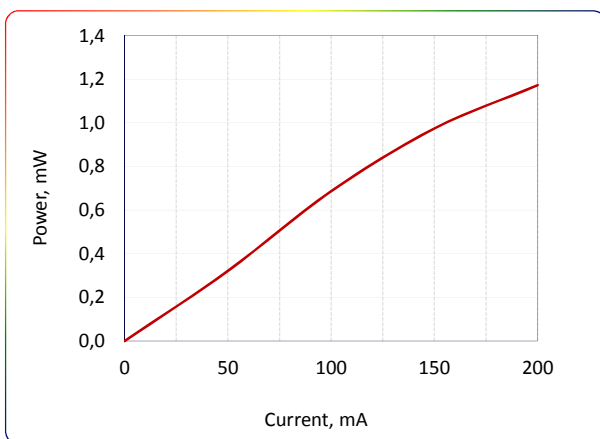

LED Typical Current-Voltage Characteristics (T=300K)

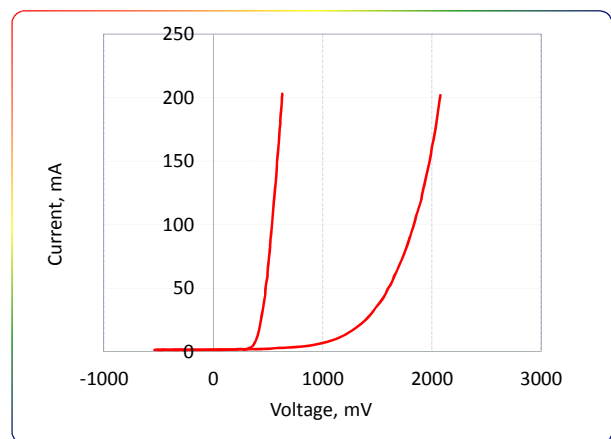

Packages	Model
TO-18 with a cap without a window	Lms MIR LED-FC
TO-18 with a parabolic reflector without a window	Lms MIR LED-FC-R
TO-18 with a parabolic reflector with a glass window	Lms MIR LED-FC-RW
TO-5 with a built-in thermocooler and thermoresistor, covered by a cap with a glass window	Lms MIR LED-FC-TEM
TO-5 with a built-in thermocooler and thermoresistor, covered by a parabolic reflector with a glass window	Lms MIR LED-FC-TEM-R

Beam Divergence (Far-field pattern)

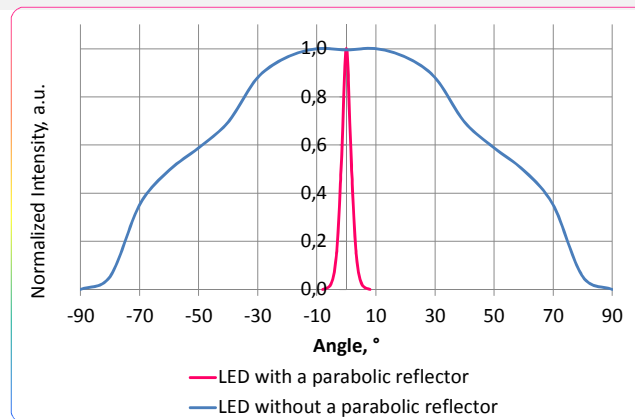

To drive the LED we recommend to use:

• LED basic circuit connection

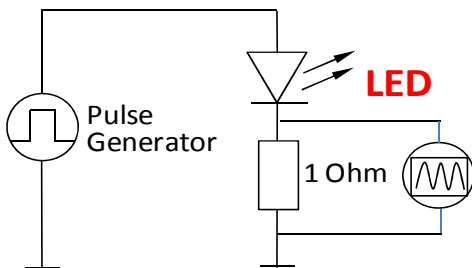

• LED with thermoelectric module basic circuit connection

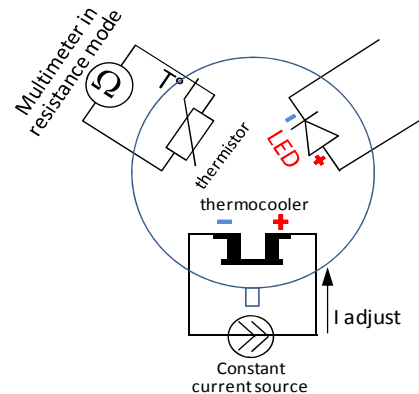

• LED drivers and evaluation boards
designed by LED Microsensor NT

We recommend to use Quasi Continuous Wave (qCW) mode with duty cycle 50% or 25% to obtain maximum average optical power and short Pulse modes to obtain maximum peak power. Hard CW (continius wave) mode is NOT recommended.

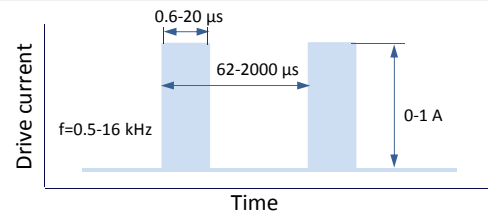
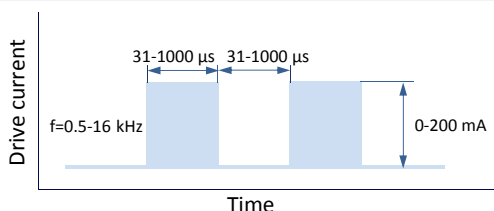

IMPORTANT CAUTIONS:

- Please check your connection circuit before turning on the LED
- Please observe the LED polarity: LED anode is marked with a RED dot
- Please do not connect the LED to the multimeter

Technical Drawings

Lms MIR LED-FC

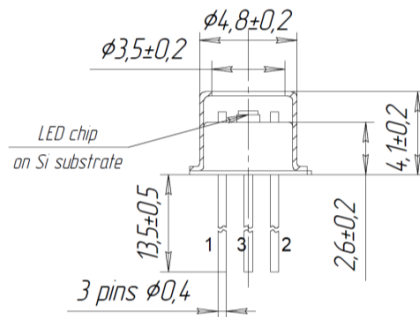
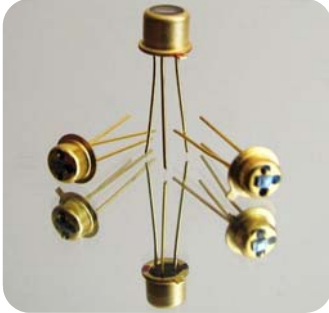

BOTTOM VIEW

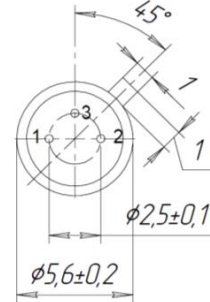

- 1 - LED anode
- 2 - LED cathode
- 3 - ground pin

Lms MIR LED-FC-R
Lms MIR LED-FC-RW

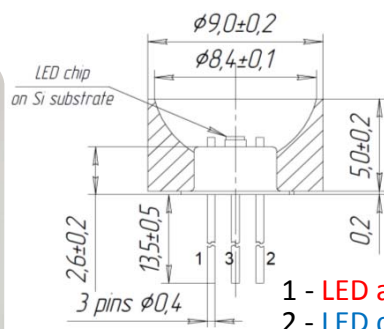
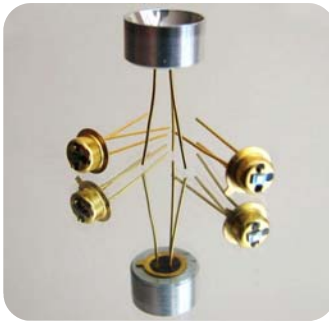

- 1 - LED anode
- 2 - LED cathode
- 3 - ground pin

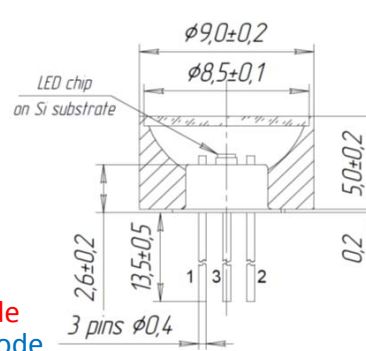

BOTTOM VIEW

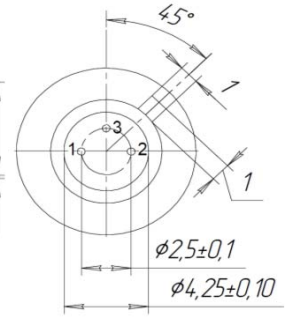

Lms MIR LED-FC-TEM

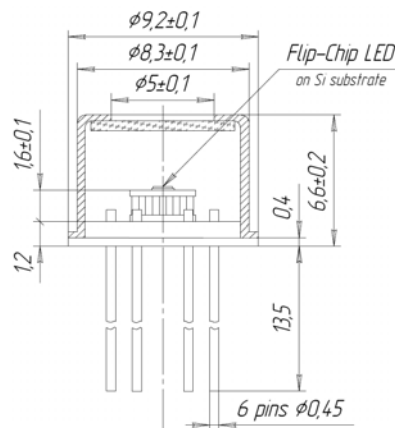
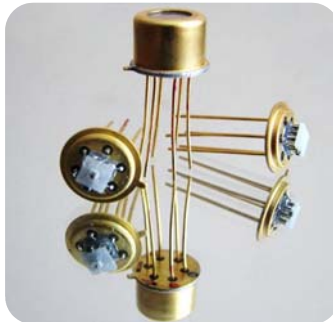

TOP VIEW

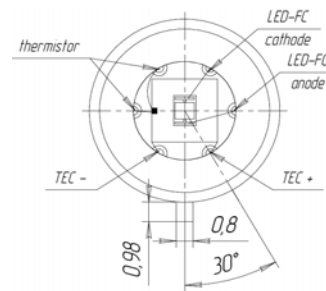

Lms MIR LED-FC-TEM-R

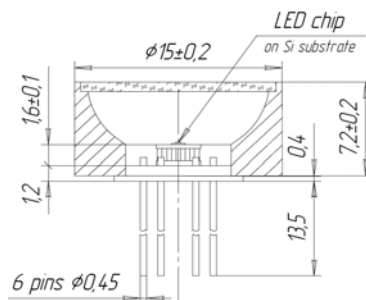
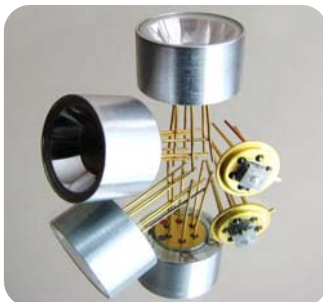

TOP VIEW

