

Lms36PD-03-R-PA and Lms36PD-03-RW-PA



Device parameters		Symbol	Value	Units
Sensitive area size		d	0.3	mm
Reverse voltage		operated unbiased ($V_r = 0$)		
Operating/ storage temperature	Lms36PD-03-R-PA	T_{opr}/T_{stg}	0..+50	$^{\circ}\text{C}$
	Lms36PD-03-RW-PA		+5..+50	

All parameters refer to photodiode operation at ambient temperature 25 $^{\circ}\text{C}$ unless otherwise stated.

Photodiode parameters	Conditions	Symbol	Value	Units
Cut-off wavelength (at 10% level) ¹	-	λ_{cut}	3.7 - 3.8	μm
Max. sensitivity range (at 80% level) ¹	-	λ_p	2.45 - 3.30	μm
Dark current (typical/ maximal) ²	$V_r = 0.1\text{ V}$	I_d	typ 150 / max 600	μA
Shunt resistance (minimal/ typical) ²	$V_r = 10\text{ mV}$	R_{sh}	min 0.2 / typ 0.6	$\text{k}\Omega$
Capacitance (typical/ maximal) ¹	$V_r = 10\text{ mV}$	C	typ 200 / max 300	pF
Photosensitivity (minimal/ typical) ²	$\lambda = 3.3\ \mu\text{m}$	S	min 0.7 / typ 0.8	A/W
Noise equivalent power (typical/ maximal) ²	$\lambda = 3.3\ \mu\text{m}$	NEP	typ $6.5 \cdot 10^{-12}$ / max $13 \cdot 10^{-12}$	$\text{W/Hz}^{1/2}$
Detectivity (minimal/ typical) ²	$\lambda = 3.3\ \mu\text{m}$	D^*	min $2.4 \cdot 10^9$ / typ $4.7 \cdot 10^9$	$\text{cm}^2 \cdot \text{Hz}^{1/2} \cdot \text{W}^{-1}$

¹ Parameter tested for representative sampling.

² Parameter tested for each device.

Typical spectral response

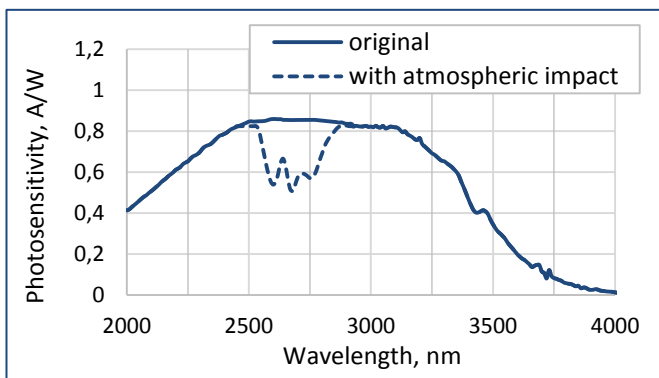

Typical current-voltage characteristic

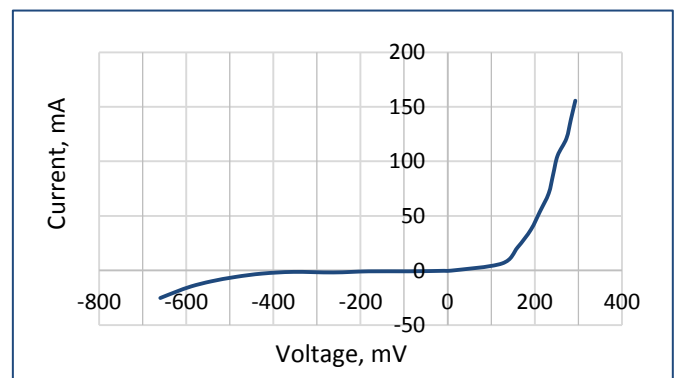

Temperature shift of spectral response

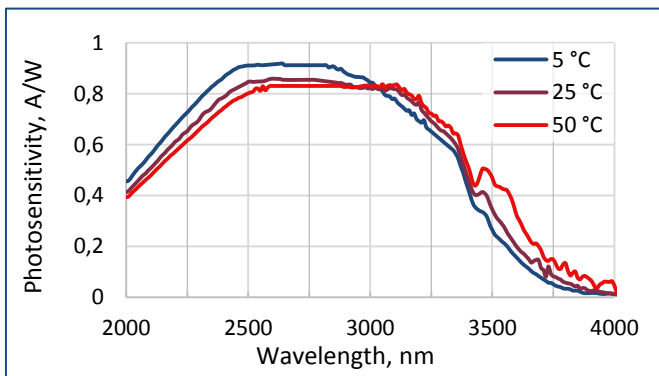

Capacitance vs. voltage

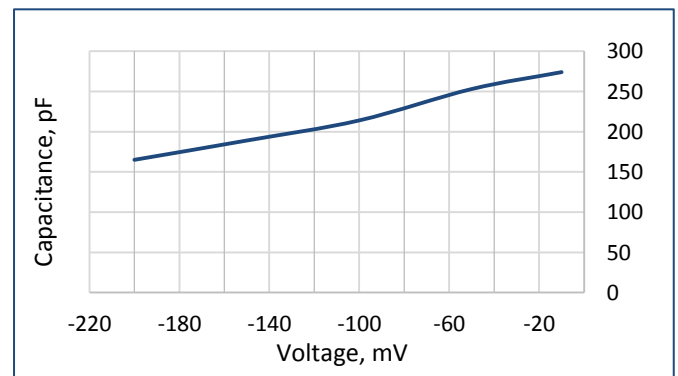

Packages*	Model
TO-18 with a cap without a glass window	Lms36PD-03
TO-18 with a parabolic reflector without a glass window	Lms36PD-03-R
TO-18 with a parabolic reflector with a glass window	Lms36PD-03-RW
TO-5 with a built-in thermocooler and thermoresistor, covered by a cap with a glass window	Lms36PD-03-TEM
TO-5 with a built-in thermocooler and thermoresistor, covered by a parabolic reflector with a glass window	Lms36PD-03-TEM-R
PD with a built-in preamplifier; TO-18 with a parabolic reflector without a window in an aluminum tube	Lms36PD-03-R-PA
PD with a built-in preamplifier; TO-18 with a parabolic reflector with a window in an aluminum tube	Lms36PD-03-RW-PA

*Standard photodiode packaging is non-hermetical, so that condensation during device operation and storage must be prevented.

Operation mode of photodiode with a built-in preamplifier

Photodiode models with LMSNT preamplifier (-PA) work in photovoltaic mode. Current generated by photodiode is amplified and converted by preamplifier into voltage signal. There is straight correspondence between PD current and resulting output voltage. The signal converted by preamplifier will have the same form, frequency and pulse duration as the photocurrent signal from photodiode. Current into voltage conversion coefficient is constant and depends on given photodiode.

NOTE! Preamplifier is typically tuned for operation with an LED emitter working in a pulse mode with 0.5 kHz frequency and 20 μs pulse duration. Tuning for other operation modes is available under special request.

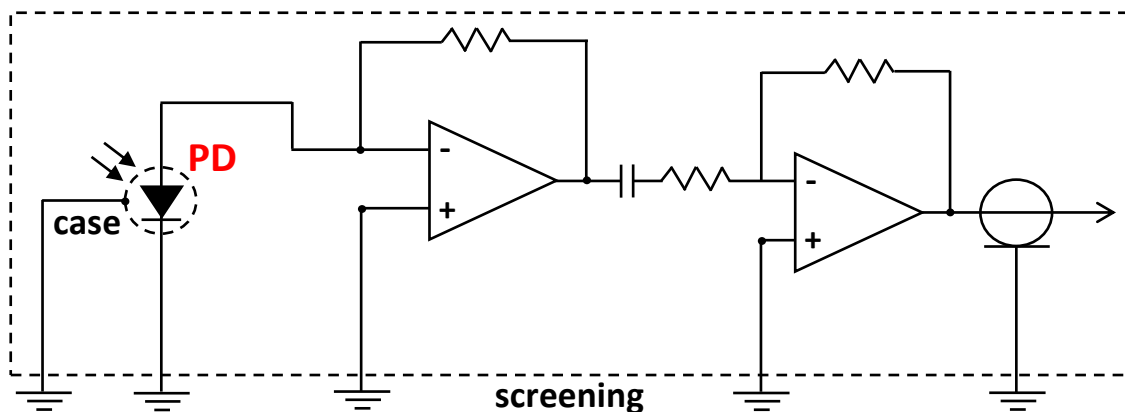

Power input voltage: +5 V, stabilized;

Connections:

The output of PD with a built-in preamplifier has four wires:

- "+" power input (to the "+5V" of the power output terminal block of the SDM synchronous detector);
- "ground" power input (to the "0V" of the power output terminal block of the SDM synchronous detector);
- "ground" output photodiode signal (to the "0V" of the signal input terminal block of the SDM synchronous detector);
- "+" output photodiode signal (to the "IN" of the signal input terminal block of the SDM synchronous detector).

For the proper connection mind the colours of the wires pointed in the technical data provided with the photodiode.

IMPORTANT CAUTIONS:

- please check your connection circuit before turning on the PD;
- please do not connect the PD to the multimeter.

Technical Drawing

Lms36PD-03-R-PA

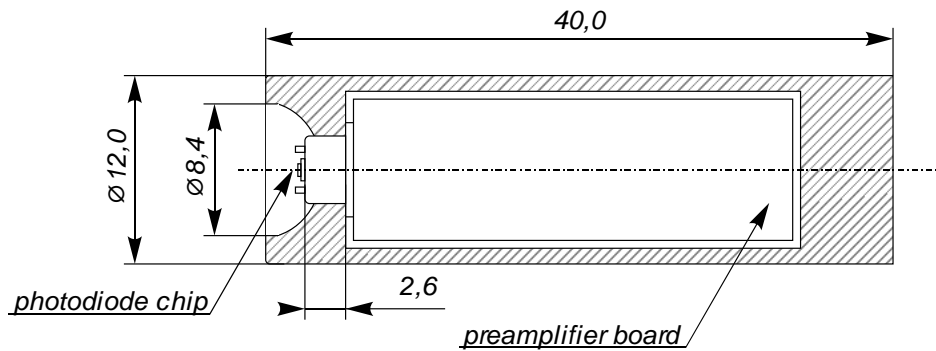

Lms36PD-03-RW-PA

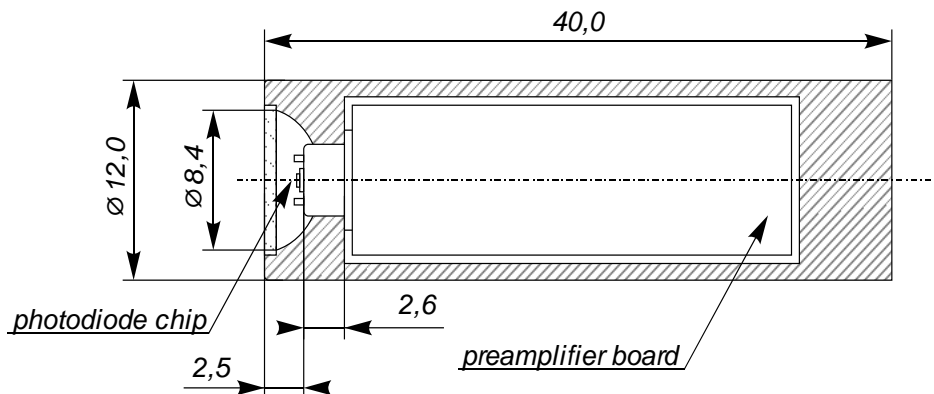

Related products:

- **Light emitting diodes (LEDs)** - sources of IR radiation;
- **SDM synchronous detector** - enables synchronous operation of a PD coupled with a preamplifier and an LED coupled with a driver; performs conversion of an output PD preamplifier signal into DC voltage signal.