

Lms36PD-03-CG-R-PA

Device parameters	Symbol	Value	Units
PD chip sensitive area size	d	0.3	mm
Operating/ storage temperature	$T_{\text{opr}}/ T_{\text{stg}}$	0..+50	$^{\circ}\text{C}$
Reverse voltage	operated unbiased ( $V_r = 0$ )		

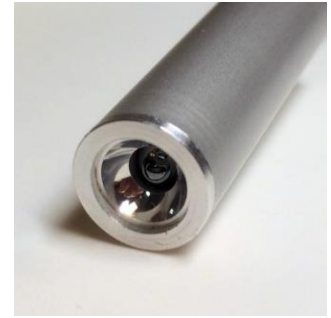

All parameters refer to photodiode operation at ambient temperature 25 $^{\circ}\text{C}$  unless otherwise stated.

Photodiode parameters	Conditions	Symbol	Value	Units
Cut-off wavelength (at 10% level) <sup>1</sup>	-	$\lambda_{\text{cut}}$	3.7 - 3.8	$\mu\text{m}$
Max. sensitivity range (at 80% level) <sup>1</sup>	-	$\lambda_p$	2.4 - 3.1	$\mu\text{m}$
Dark current (typical/ maximal) <sup>2</sup>	$V_r = 0.1 \text{ V}$	$I_d$	typ 80 / max 300	$\mu\text{A}$
Shunt resistance (minimal/ typical) <sup>2</sup>	$V_r = 10 \text{ mV}$	$R_{\text{sh}}$	min 0.4 / typ 1.5	$\text{k}\Omega$
Capacitance (typical/ maximal) <sup>1</sup>	$V_r = 10 \text{ mV}$	C	typ 250 / max 300	$\text{pF}$
Noise equivalent power (typical/ maximal) <sup>2,3</sup>	$\lambda = 3.3 \mu\text{m}$	NEP	typ $2.5 \cdot 10^{-13}$ / max $9.6 \cdot 10^{-13}$	$\text{W}/\text{Hz}^{1/2}$
Detectivity (minimal/ typical) <sup>2,3</sup>	$\lambda = 3.3 \mu\text{m}$	$D^*$	min $3.2 \cdot 10^{10}$ / typ $1.2 \cdot 10^{11}$	$\text{cm}^2 \cdot \text{Hz}^{-1/2} \cdot \text{W}^{-1}$

<sup>1</sup> Parameter tested for representative sampling.

<sup>2</sup> Parameter tested for each device.

<sup>3</sup> Parameters are calculated using photosensitivity value [A/W] obtained for the same photodiode prior to glass covering multiplied by the coefficient equal to the ratio of response of PD with and without glass covering (measured at  $\lambda = 3.3 \mu\text{m}$ ).

Typical spectral response

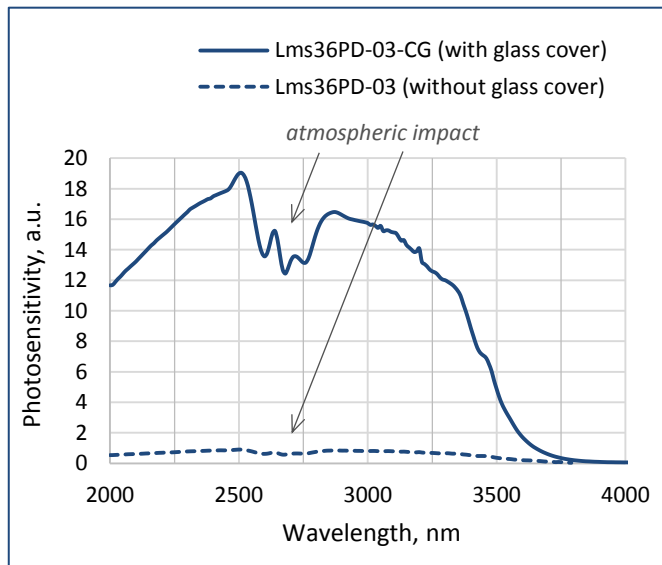

Typical current-voltage characteristic

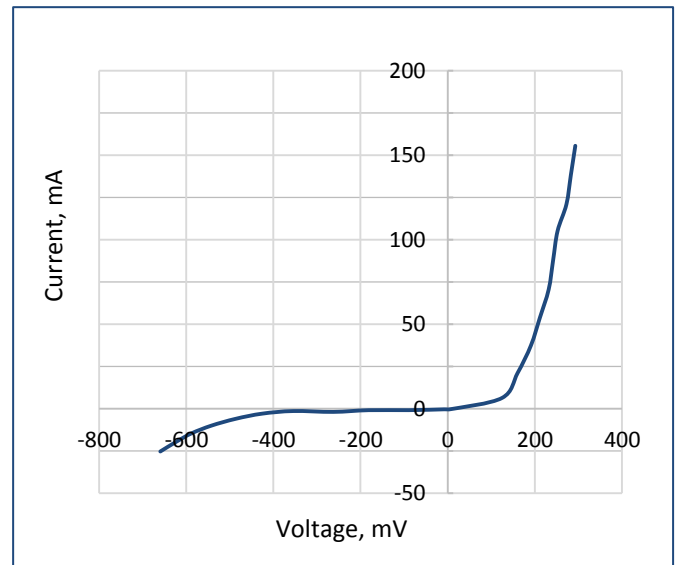

Packages	Model
TO-18 with glass cover	Lms36PD-03-CG
PD with built-in preamplifier; TO-18 with a glass cover and a parabolic reflector without a window in an aluminium tube	Lms36PD-03-CG-R-PA

### Operation mode of photodiode with a built-in preamplifier

Photodiode models with LMSNT preamplifier (-PA) work in photovoltaic mode. Current generated by photodiode is amplified and converted by preamplifier into voltage signal. There is straight correspondence between PD current and resulting output voltage. The signal converted by preamplifier will have the same form, frequency and pulse duration as the photocurrent signal from photodiode. Current into voltage conversion coefficient is constant and depends on given photodiode.

**NOTE!** Preamplifier is typically tuned for operation with an LED emitter working in a pulse mode with 0.5 kHz frequency and 20  $\mu\text{s}$  pulse duration. Tuning for other operation modes is available under special request.

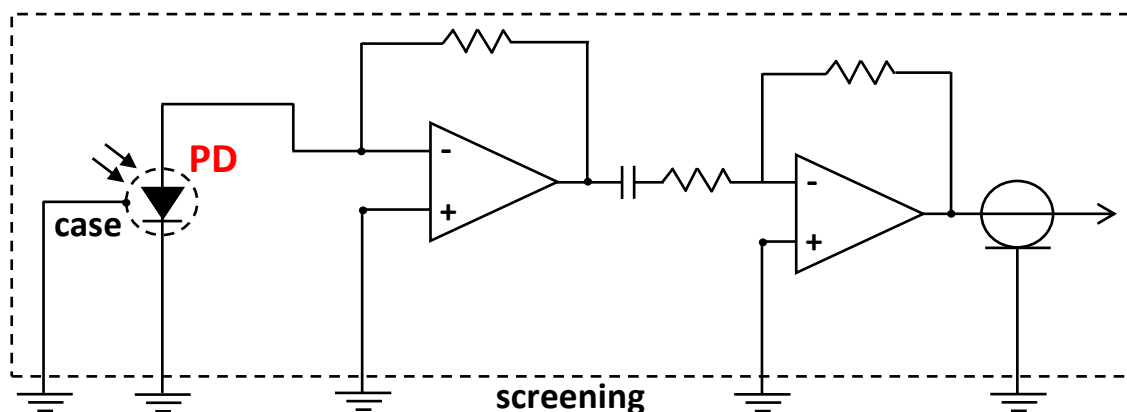

**Power input voltage:** +5 V, stabilized;

#### Connections:

The output of PD with a built-in preamplifier has four wires:

- "+" power input (to the "+5V" of the power output terminal block of the SDM synchronous detector);
- "ground" power input (to the "0V" of the power output terminal block of the SDM synchronous detector);
- "ground" output photodiode signal (to the "0V" of the signal input terminal block of the SDM synchronous detector);
- "+" output photodiode signal (to the "IN" of the signal input terminal block of the SDM synchronous detector).

**For the proper connection mind the colours of the wires pointed in the technical data provided with the photodiode.**

### IMPORTANT CAUTIONS:

- check your connection circuit before turning on the PD;
- mind the PD polarity: PD anode is marked with a RED dot;
- do not connect the PD to the multimeter;
- do not touch the glass covering and do not apply any force to it;
- observe the allowable operating temperature range, exceeding this range may cause irreparable damage of the glass cover

Technical Drawing

Lms36PD-03-CG-R-PA

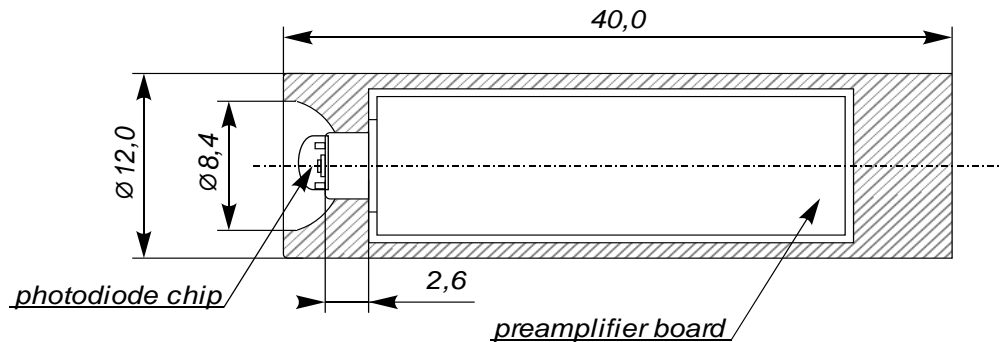

Related products:

- **Light emitting diodes (LEDs)** - sources of IR radiation;
- **SDM synchronous detector** - enables synchronous operation of a PD coupled with a preamplifier and an LED coupled with a driver; performs conversion of an output PD preamplifier signal into DC voltage signal.